

Heidelberg Wallbox Energy Control - Commissioning

This brief installation instruction provides a quick overview of all the necessary steps. Additional information, references, and sources can be found in our [HelpCenter](#). The Installation instructions are only valid for the integration of the energy management system and the configuration of relevant assets. Make sure to carefully read the [safety instructions](#) and adhere to the [Infrastructural requirements for a gridBox gateway installation](#)

Required:

- Latest firmware
- additional USB-RS485 and a shielded cable



Connection

The connection of the charging station to the gridBox is done via a serial interface Modbus-RTU (RS485). Up to 16 charging stations can be used on one USB-RS485 adapter. The connections for the data line are located in the charging point at position 4:

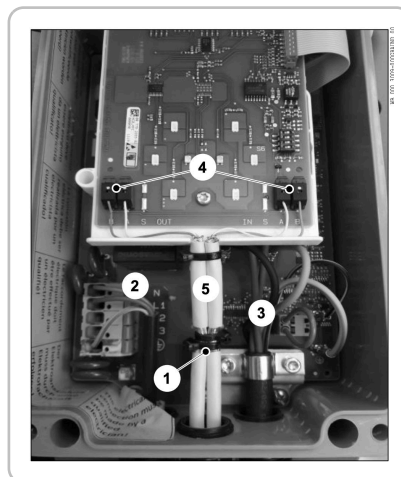

The wiring is done according to this scheme:¹

¹Externes-Lastmanagement-DEU_00.pdf, p. 12

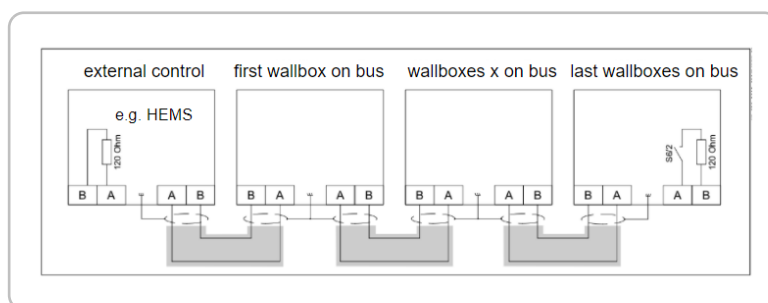

For the last charging station as well as for the USB-RS485 adapter, a bus termination must be added. To do this for the charging station, set the 2nd switch of switch group S6 to "On".

Configuration

The configuration of the charging point is done via several micro switches (DIP switch) and a rotary switch (S1):²

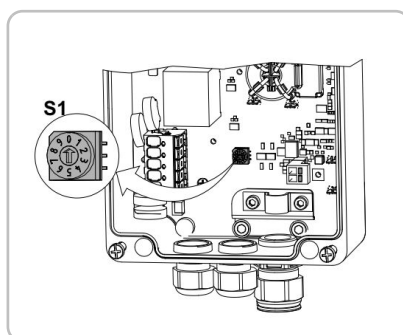

The rotary switch S1 is used to set the maximum charging current from 6 to 16 A:

Setting	Charging current
0	6 A (default setting, delivery state)
1	8 A
2	10 A
3	12 A
4	14 A
5 ... 9	16 A

All rotary and microswitches in OFF position:³

²Externes-Lastmanagement-DEU_00.pdf, p.7

³Externes-Lastmanagement-DEU_00.pdf, p. 7

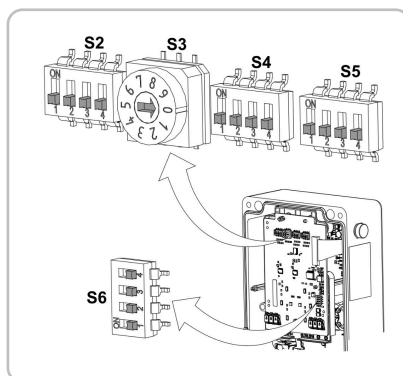

S2	Configuration bus ID 16
S3	Setting for minimum charging current
S4	Configuration of bus ID 1 to 15
S5	Setting leader or follower front lighting
S6	Bus termination ON/OFF

Modbus settings

1. Define the charging point as a "follower wallbox" to control it.
2. Set the 2nd, 3rd and 4th switch of switch group S5 to "off" and the 1st switch to "on".
3. Set the bus ID of the station via switch group S4 or via S2.
4. Make sure that no bus ID is duplicated and that ID 0 is not used.

The following table shows the necessary switch positions for a certain bus ID. A special case is Bus ID 16, which can be defined via switch group S2. If Bus ID 16 was defined via the switch group S2, all switches from group S4 are ignored.

BUS-ID	S4/1	S4/2	S4/3	S4/4
0	OFF	OFF	OFF	OFF
1	OFF	OFF	OFF	ON
2	OFF	OFF	ON	OFF
3	OFF	OFF	ON	ON
4	OFF	ON	OFF	OFF
5	OFF	ON	OFF	ON
6	OFF	ON	ON	OFF
7	OFF	ON	ON	ON
8	ON	OFF	OFF	OFF
9	ON	OFF	OFF	ON
10	ON	OFF	ON	OFF
11	ON	OFF	ON	ON
12	ON	ON	OFF	OFF
13	ON	ON	OFF	ON
14	ON	ON	ON	OFF
15	ON	ON	ON	ON

BUS-ID	S2/1	S2/2	S2/3	S3/4
16	OFF	OFF	OFF	ON

Load settings

The relation of switch position to power is identical for both switches, and is as follows:

Switch position	Power
0 (default)	6 ampere
1	8 ampere
2	10 ampere
3	12 ampere
4	14 ampere
5-9	16 ampere